

# Arkansas Department of Human Services

## Minimal Essential Coverage 1095-B Compliance

### Process Flow Narrative

**Version 1.6**  
**Date:** May 20, 2018



## Contents

<b>1.0 INTRODUCTION</b> .....	<b>1</b>
<b>2.0 DOCUMENT OVERVIEW</b> .....	<b>1</b>
2.1 <i>HIGH-LEVEL FORM PROCESS</i> .....	1
2.2 <i>HIGH-LEVEL FLOW</i> .....	2
2.3 <i>AWARDEE PROCESS</i> .....	3
2.4 <i>AWARDEE FLOW</i> .....	4
2.5 <i>IRS REPORTING PROCESS</i> .....	4
2.6 <i>IRS REPORTING FLOW</i> .....	5
2.7 <i>IRS AIR PROCESS</i> .....	5
2.8 <i>IRS AIR FLOW</i> .....	6
2.9 <i>DCFS PROCESS</i> .....	6
2.10 <i>DCFS FLOW</i> .....	7
2.11 <i>RETURN MAIL PROCESS</i> .....	8
2.12 <i>RETURN MAIL FLOW</i> .....	9
<b>3.0 SECURITY</b> .....	<b>9</b>
3.1 <i>SECURITY PROCESS - IRS REPORTING</i> .....	9
3.2 <i>SECURITY FLOW – IRS REPORTING</i> .....	11
<b>4.0 TECHNICAL REQUIREMENTS</b> .....	<b>11</b>

## Figures

Figure 1: High-Level Form Process.....	2
Figure 2: Awardee Process .....	4
Figure 3: IRS Reporting Process.....	5
Figure 4: IRS AIR.....	6
Figure 5: DCFS Process.....	7
Figure 6: Return Mail Process .....	9
Figure 7: Security Flow - IRS Reporting.....	11

## 1.0 INTRODUCTION

Under the Affordable Care Act (ACA), beginning with the 2015 calendar year, insurers/coverage providers are required to provide coverage information for each month a person has coverage during the year. For the Arkansas Department of Human Services/Division of Medical Services (DHS/DMS), this information will be provided via Form 1095-B. Form 1095-B will be mailed via the United States Postal Service to all members who had qualifying minimal essential coverage for the respective calendar year.

The project is a coordinated effort between the Internal Revenue Service (IRS), DHS divisions and DHS vendors. The DHS divisions are the Division of County Operations (DCO), the Division of Children and Family Services (DCFS), the DHS Office of Communications and Community Engagement and DMS. DHS vendors include Optum (which operates the Decision Support System and Services (DSS) Lab), the MMIS (Medicaid Management Information System) vendor DXC (DXC Technology) and Awardee.

## 2.0 DOCUMENT OVERVIEW

The Process Flow Narrative details the transmission of data and physical documentation in relation to the 1095B compliance of Affordable Care Act (ACA). The following processes illustrate and define the various methods data and physical documentation is transmitted by various systems and vendors.

### 2.1 High-Level Form Process

The image illustrated in Figure 1: High-Level Form Process depicts the flow at a high level through various parties.

- The Division of County Operations (DCO) receives Recipient E&E (Eligibility & Enrollment) documentation from the recipient and is input into either the ANSWER or Cúram systems.
- The Recipient E&E data is sent from the DCO ANSWER or Cúram systems to DXC (DXC Technology) and is input into MMIS (Medicaid Management Information System).
- The eligibility data from the DXC MMIS is sent daily in an automated batch cycle directly to Optum's DSS (Decision Support System and Services) where a data feed is created.
- The data feed is provided to Awardee for printing of the Form 1095-B and the respective envelope, and uploaded to the portals hosted by Awardee.
- The envelope and Form 1095-B is mailed to the recipient and/or accessible to the recipient via the portals.
- The Form 1095-B is also available to DXC Call Center and DMS (Division of Medical Services) via their respective portals for triaging of Form 1095-B issues.
- The data from Awardee is transmitted to DMS in two separate forms:
  - File(s) containing errors in the data are sent to DMS for triaging
  - File(s) containing data for IRS submission to are sent to DMS
- The triaged data is resent through the process in order to transmit a corrected form
- The IRS submission is transmitted to the IRS via the IRS AIR (ACA Information Returns) system web portal

**2.2 High-Level Flow**

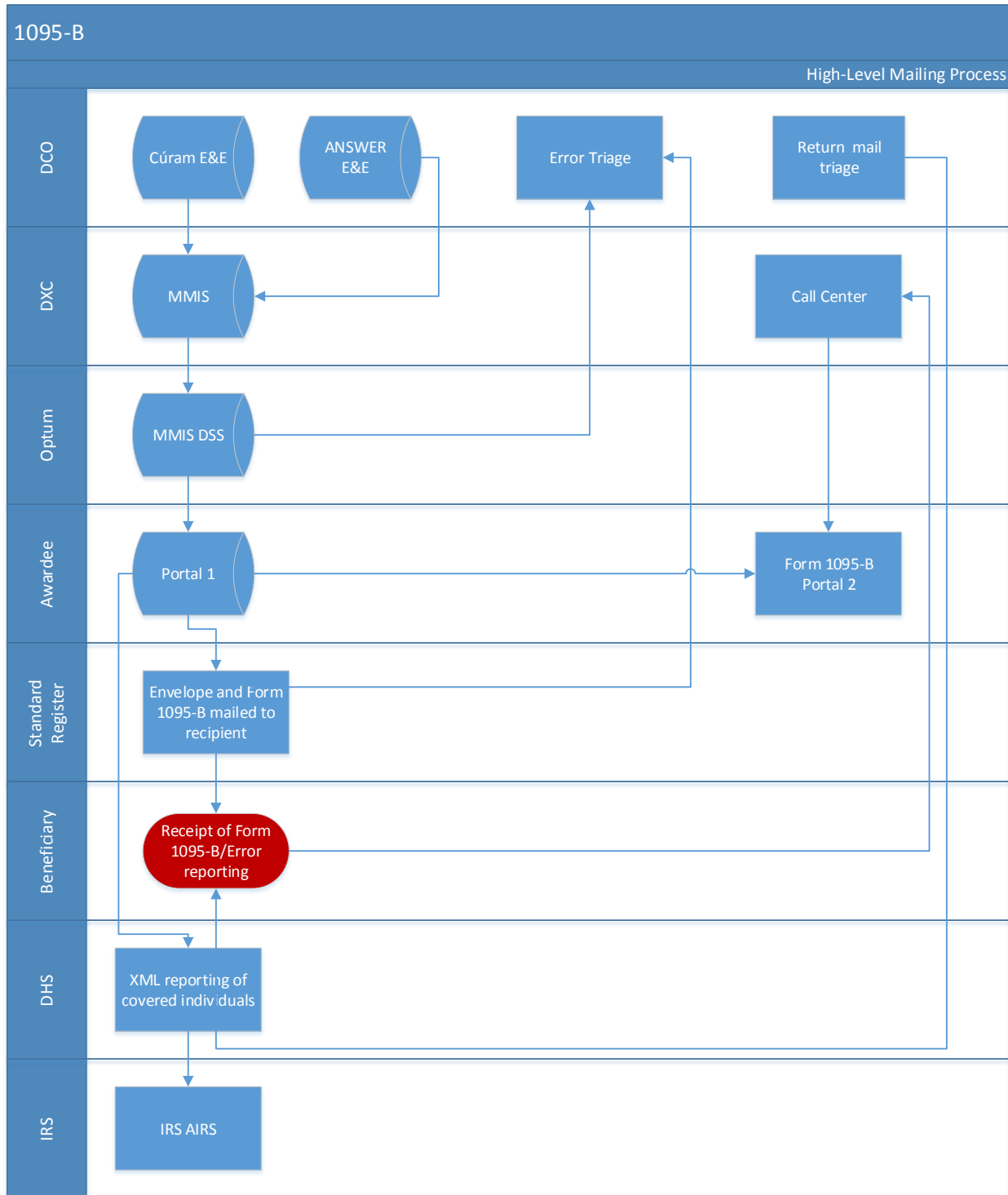

**Figure 1: High-Level Form Process**

### 2.3 Awardee Process

The image illustrated in Figure 2: Awardee Process depicts the flow of data and physical documentation through Awardee.

- The Division of County Operations (DCO) receives Recipient E&E (Eligibility & Enrollment) documentation from the recipient and is input into either the ANSWER or Cúram systems.
- The Recipient E&E data is sent from the DCO ANSWER or Cúram systems to DXC (DXC Technology) and is input into MMIS (Medicaid Management Information System).
- The eligibility data from the DXC MMIS is sent daily in an automated batch cycle directly to Optum's DSS (Decision Support System and Services) where a data feed is created. Optum creates a file from the data feed and transmits to Awardee via Accellion.
- Awardee processes the file and provides operational reports to DCO and Optum containing the data that is unable to be processed due to errors in the data. The data that passed testing is uploaded to the portals hosted by Awardee and sent to printing company.
- The printing company prints Form 1095-B and the respective envelope and mails to the recipients.
- Awardee generates an IRS XML file containing recipient mailing information and sends to DCO.
- DCO submits the IRS XML file via the IRS AIR system.
- DCO edits recipient data upon request of the recipient using the Awardee portals. The edited data is sent from Awardee to Optum in the form of a NAC (Name & Address Change) Report.
- The NAC Report data is entered into ANSWER and/or Cúram. The corrected recipient data is reprocessed and a corrected Form 1095-B is sent to the recipient and uploaded to the portals.



- DCO logs into IRS AIR system to retrieve the transmission status. The files that are “Accepted” complete the IRS reporting process. An Error Detail Report is generated for files that are rejected for errors.
- DCO processes the Error Detail Report and triages the errors contained therein. The corrected data is reprocessed.

## 2.6 IRS Reporting Flow

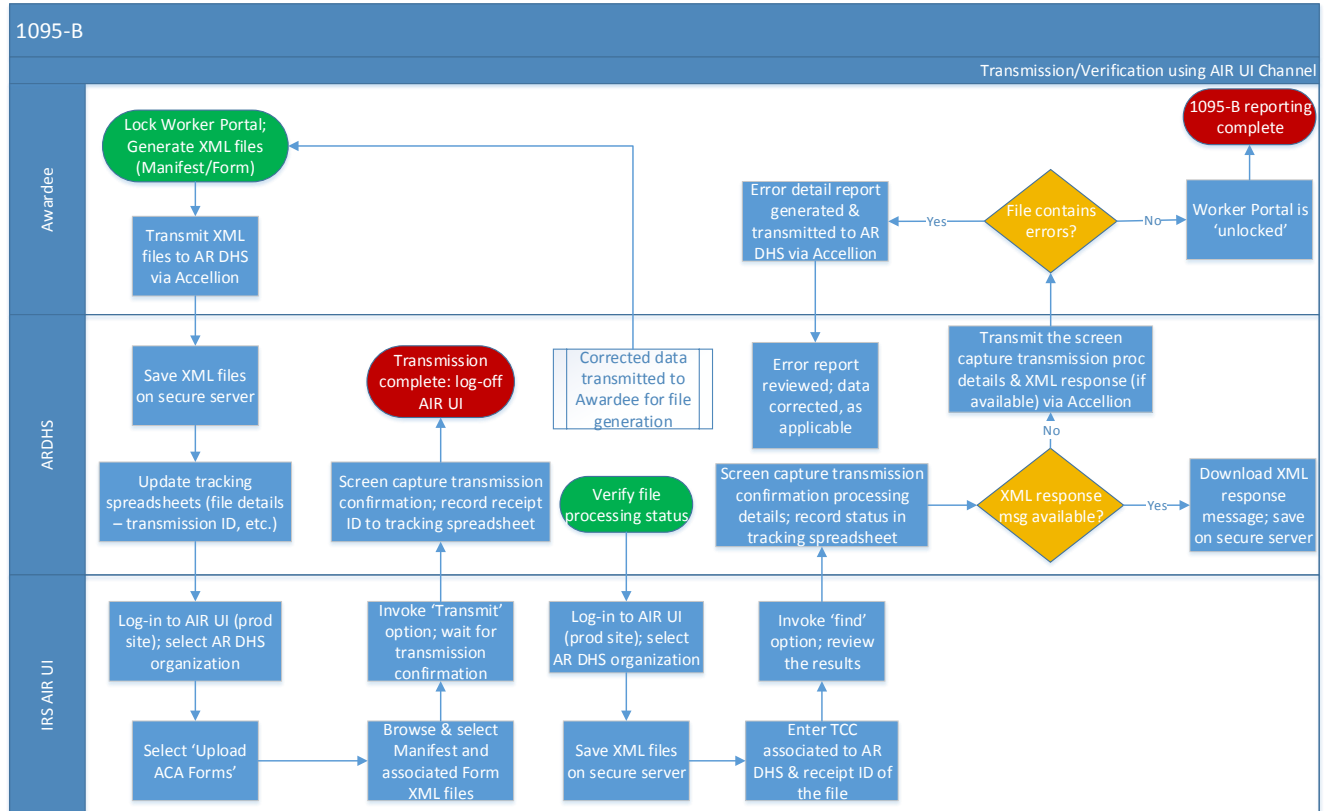

Figure 3: IRS Reporting Process

## 2.7 IRS AIR Process

The image illustrated in Figure 4: IRS AIR depicts the flow of data within the IRS AIR system.

- DCO uploads the XML file containing the Manifest and Form Data files via the IRS AIR system user interface.
- The IRS processes the XML file submission and generates a Transmission Confirmation containing a Receipt ID (RID) for each submission.
- DCO logs into IRS AIR system to retrieve the transmission status. The files that are “Accepted” complete the IRS reporting process. An Error Detail Report is generated for files that are rejected for errors.
- Files that were rejected for errors are triaged and processed for resubmission.

## 2.8 IRS AIR Flow

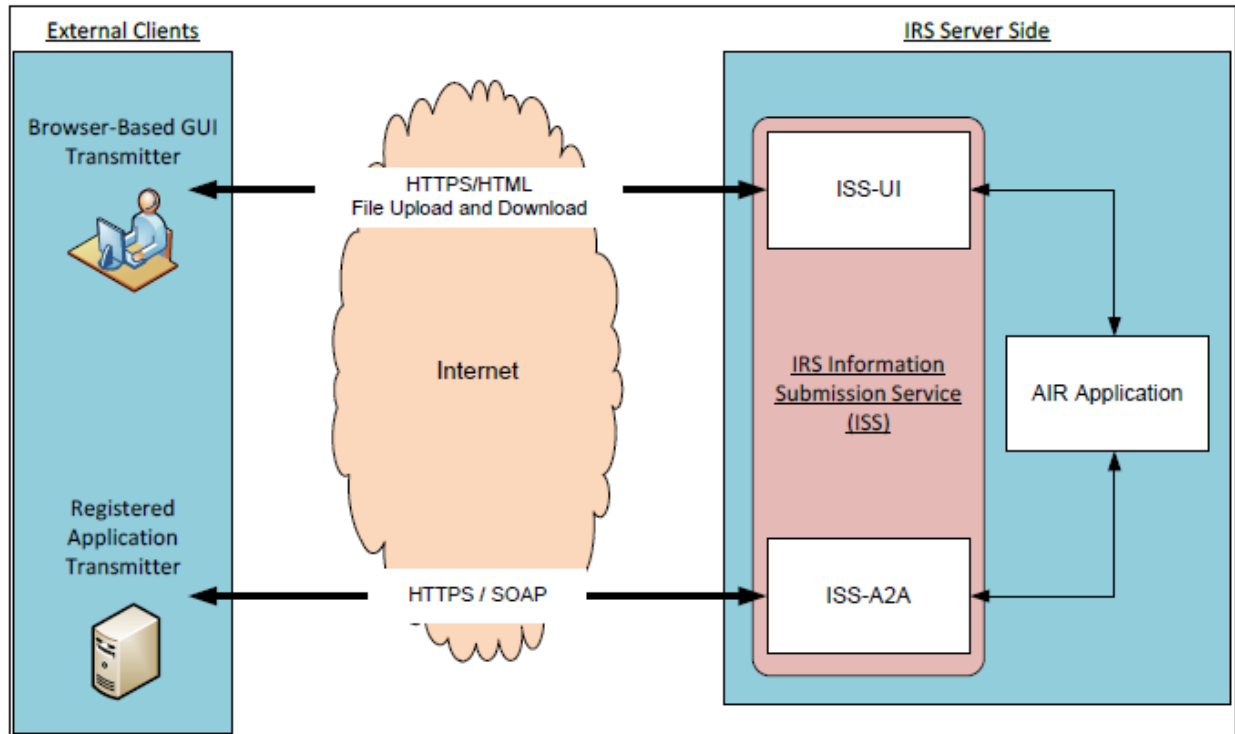

**Figure 2-1: External Clients and IRS AIR**

**Figure 4: IRS AIR**

## 2.9 DCFS Process

The Division of Children and Family Services (DCFS) provides services for the youth and children sector of Arkansas. Specifically, in relation to the foster and adopted children components of DCFS, additional steps must be completed to ensure privacy and security when transmitting Form 1095-B. The steps are outlined as follows and depicted in **Error! Reference source not found.**:

- The Division of Children and Family Services (DCFS) receives Recipient E&E (Eligibility & Enrollment) documentation from the recipient and is input into CHRIS (Children’s Reporting and Information System).
- A subset of the recipient data is pulled from CHRIS and entered into an excel spreadsheet. The spreadsheet is sent to Optum via Accellion.
- Optum reviews the spreadsheet and notes the distinction as to whether the recipient is foster or adopted.
  - If the recipient is classified as ‘adopted’, Optum compares the recipient address from the spreadsheet to the address listed in the DSS extract. If the addresses match, the DSS extract is sent to Awardee. If the addresses do not match, the address from the



- spreadsheet is used for the data feed extract. The DSS extract is then sent to Awardee via Accellion.
- If the recipient is classified as ‘adopted’, Awardee creates a data file and sends to print company for printing and mailing.
  - Awardee reviews the extract and notes the distinction as to whether the recipient is classified as ‘foster’.
    - If the recipient is classified as ‘foster’, Optum sets a ‘no mail’ flag for the recipient and overlays the address that is listed in the DSS extract with a DHS address. The DSS extract is then sent to Awardee via Accellion.
    - If the recipient is classified as ‘foster’, Awardee uploads the recipient Form 1095-B to the portals.

## 2.10 DCFS Flow

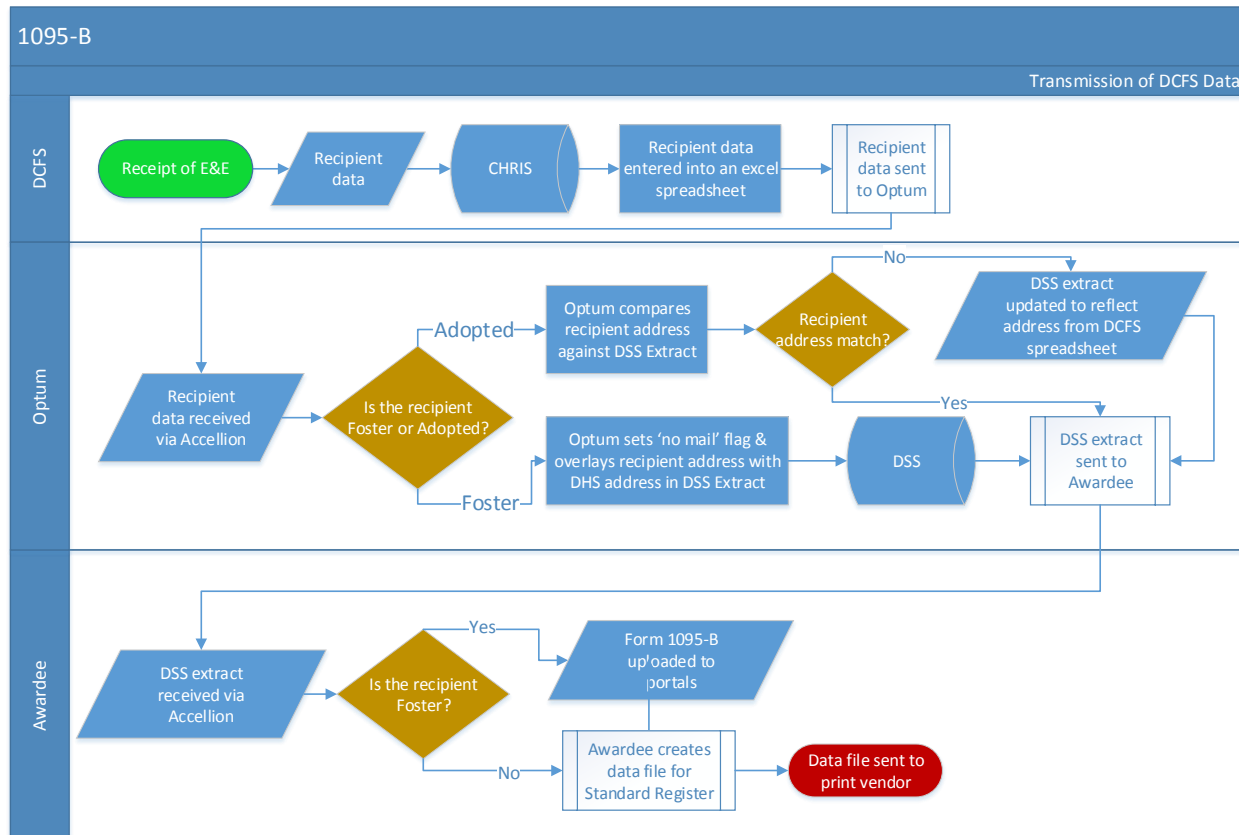

Figure 5: DCFS Process

## 2.11 Return Mail Process

Form 1095-B is provided to recipients via electronic format and/or physically mailed. When a physically-mailed form is undeliverable and returned, the form is processed in an effort to obtain valid data to resend to the recipient. The steps are outlined as follows and depicted in **Error! Reference source not found.**:

- The Division of County Operations (DCO) receives Recipient E&E (Eligibility & Enrollment) documentation from the recipient and is input into either the ANSWER or Cúram systems.
- The Recipient E&E data is sent from the DCO ANSWER or Cúram systems to DXC Technology and is input into MMIS (Medicaid Management Information System).
- The eligibility data from the DXC MMIS is sent daily in an automated batch cycle directly to Optum's DSS (Decision Support System and Services) where a data feed is created. Optum creates a file from the data feed and transmits to Awardee via Accellion.
- Awardee processes the file and uploads to the portals hosted by Awardee and sends to Standard Register printing company.
- The printing company prints Form 1095-B, the respective envelope, and mails to the recipients. The envelope is printed with a QR (Quick Response) code (similar to a bar code) to triage return mailings.
- Returned mail is received at the DXC–Little Rock location. The returned mailings are processed by running through an ADF (Automatic Document Feeder) which scans the QR code printed on the envelope. The scanned, returned mail is sent to the DOC – Pine Bluff location to begin efforts for triaging. DXC sends a file containing pertinent information derived from the scanned QR code to DCO, Optum, and Awardee, via Accellion. Optum reformats the file and adds identifiable recipient data, and then sends to DCO and Awardee, via Accellion.
- Awardee processes the file and flags the portals with a 'Return Notice'.
- DCO processes the file from Optum and begins triaging the returned mailings. The triaged returns are then reprocessed.

## 2.12 Return Mail Flow

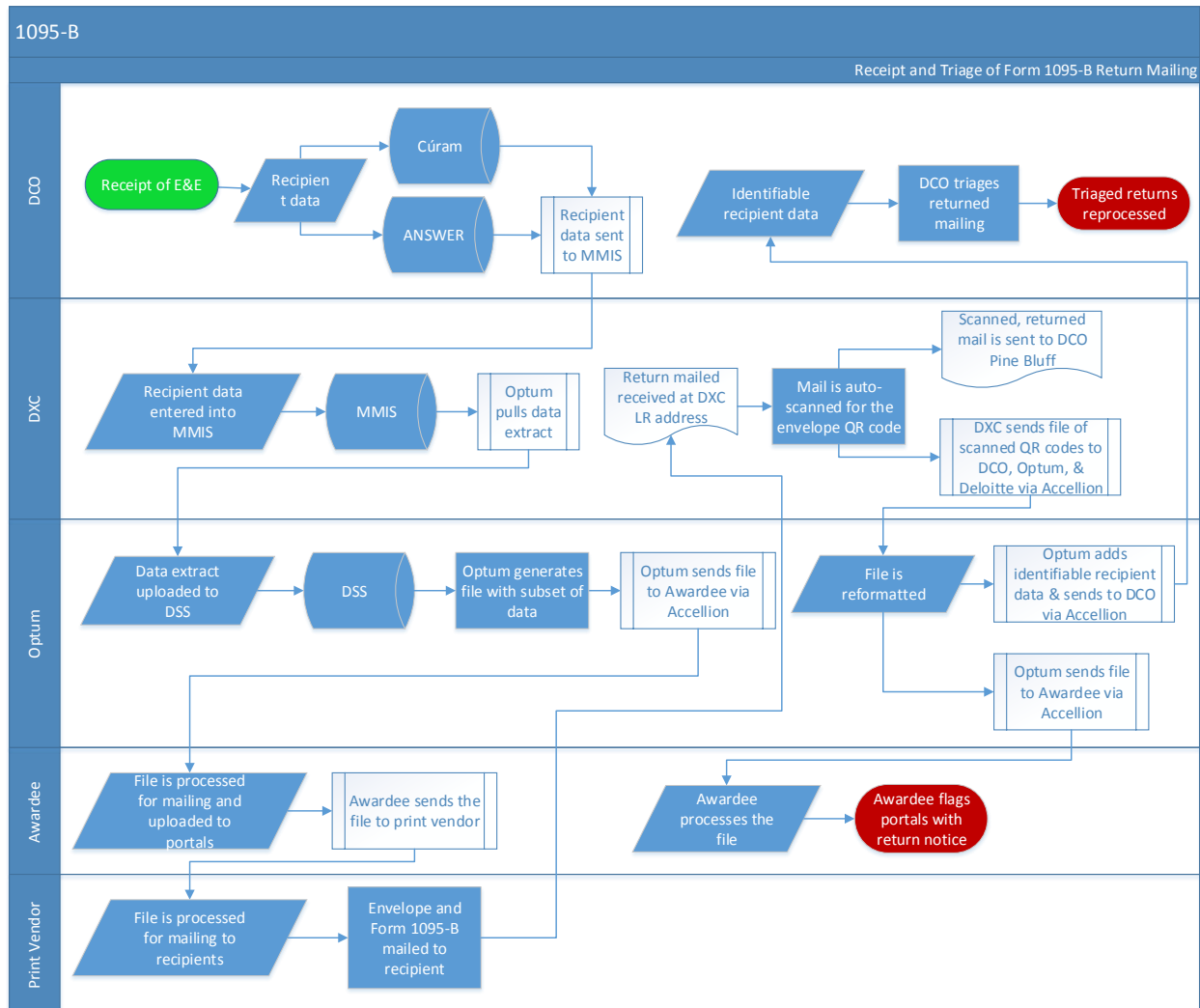

Figure 6: Return Mail Process

## 3.0 SECURITY

Section 2 outlined the flow of data and physical documentation from a systems and vendor-standpoint. Section 3 defines and depicts the processes and flows from a security standpoint.

### 3.1 Security Process - IRS Reporting

The image illustrated in Figure 7: Security Flow - IRS Reporting depicts the flow data in relation to IRS reporting compliance from a security standpoint.

- The Division of County Operations (DCO) receives Recipient E&E (Eligibility & Enrollment) data which is stored on the following:
  - EEF/Cúram (AR DIS) Arkansas Department of Information Systems network, which consists of:

- IBM HTTP (HIS) Servers – IHS1 and IHS2
- Cúram Application Servers – WAS1 and WAS2
- Cúram IDSdB and Cúram dB
- ANSPROD/ANSWER (AR DIS) network, which consists of:
  - Microfocus is used to prepare the data for online transactional processing using CICS (Customer Information Control System) for migration into the Mainframe.
  - Data from Traditional Medicaid, SNAP (Supplemental Nutrition Assistance Program), and TANF/TEA (Temporary Assistance for Needy Families/Transitional Employment Assistance) flow to the ANSPRD mainframe as well.
- The data from EEF/Cúram and ANSPRD are transmitted through the Internet using a VPN (Virtual Private Network) to the DXC MMIS.
  - The data is sent using an ARDHS (Arkansas Department of Human Services) SFTP (Secure File Transfer Protocol) approved-tool called, Accellion.
- The data from EEF/Cúram and ANSPRD are transmitted through the Internet using a VPN to the Optum DSS (Decision Support System and Services).
  - The data is sent through AR DIS (Arkansas Department of Information Systems) using an ASA (Adaptive Security Appliance) firewall with Cisco software for transmission to the ARDSH and is then transmitted using two-way TLS (Transport Layer Security) protocol to the FED DSH, and is then transmitted to the Internet with HTTPS (Hyper Text Transfer Protocol Secure).
- The data is sent from the DXC MMIS to Awardee and uploaded to the Case Worker Portal, Citizen Portal through the Internet using HTTPS/SFTP, and Accellion. The State Case Worker access the data using HTTPS authentication. No PHI is stored in the ticketing system.
- The data from Awardee is sent to the print vendor (Awardee's subcontractor) through the Internet using HTTPS/SFTP, AES 128 encryption. The print vendor has a PHI management plan which is vetted by Awardee. The print vendor discards the data upon processing in compliance with all privacy and security requirements under state and federal law.

### 3.2 Security Flow – IRS Reporting

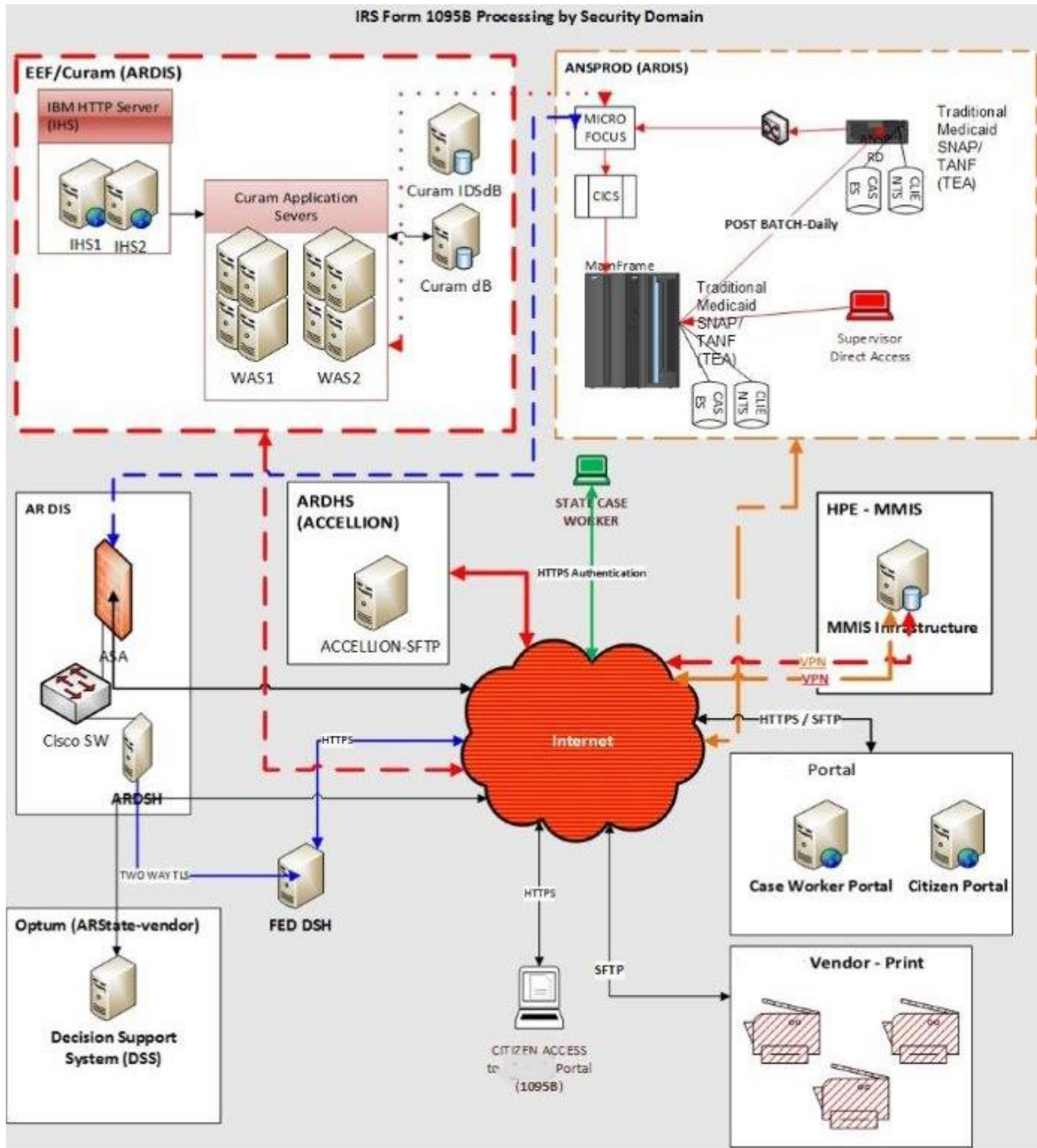

Figure 7: Security Flow - IRS Reporting

### 4.0 TECHNICAL REQUIREMENTS

Refer to [www.irs.gov](http://www.irs.gov) for technical specifications.